

# KRAFTWERK®

FAVORITE TOOLS SINCE 1979

## Instruction Manual Foldable engine crane

Art. 38127

EN



CE

## SAFETY INSTRUCTIONS

READ THESE INSTRUCTIONS CAREFULLY AND NOTE THE SAFETY INSTRUCTIONS AND WARNINGS. USE THE APPLIANCE CORRECTLY AND WITH CARE FOR THE PURPOSE FOR WHICH IT IS INTENDED. FAILURE TO DO SO MAY CAUSE DAMAGE TO PROPERTY AND/OR SERIOUS PERSONAL INJURY. KEEP THIS INSTRUCTION MANUAL SAFE FOR FUTURE USE.

- This appliance can be used by persons with reduced physical, sensory or mental capabilities or lack of experience and knowledge if they have been given supervision or instruction concerning use of the appliance in a safe way and understand the hazards involved. Children shall not play with the appliance.
- Before each use, ensure that all nuts and bolts are correctly fitted and tight.
- Before use, bleed the hand pump.
- Do not modify the appliance in any way.
- Do not operate the hoist if any parts are missing, damaged or faulty.
- Do not operate the hoist when you are tired, under the influence of alcohol, drugs or intoxicating medication.
- Keep children and unauthorized people away from the work area.
- Keep the work area clean and tidy.
- Make sure the legs and boom are locked into position before use.
- Make sure you are aware of any other people near you when you are using the hoist.
- The hoist is a lifting and lowering device only and is not intended for transporting items.
- The hoist is intended for use by qualified persons who are familiar with its use.
- The nuts and bolts used in the construction of this hoist are all high strength. They should not be replaced with any that are inferior.
- Use only on a level and firm surface. Do not use on tarmac or soft surfaces.
- Always make sure the centre of gravity remains inside the hoist base.
- Do not allow the load to drop suddenly. Open the valve slowly.
- Do not allow yourself or anyone else to be under the load.
- Do not overload.
- Do not harness the load at an angle or allow it to swing when it is lifted.
- Do not overreach.
- Do not climb or stand on the hoist.
- Ensure the surface you are lowering the load onto is level and can withstand the weight.
- Refill with hydraulic oil only, making sure no dirt gets into the hydraulic system.
- Stay alert at all times.
- Do not allow the hoist to get wet or remain in a damp environment.
- Store the machine in a secure dry place out of the reach of children.
- When not in use, release the pressure from the pump.

## TECHNICAL DATA

Art. 38127

Max. Capacity: 2000 kg

Max. lift: 2400 mm

This product fulfils the requirements of quality class HA ISO 2807.

# TECHNICAL DATA

Step 1

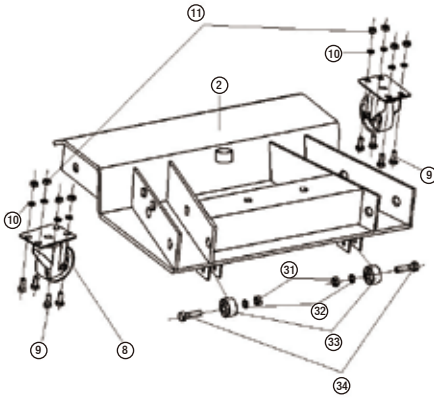

Step 2

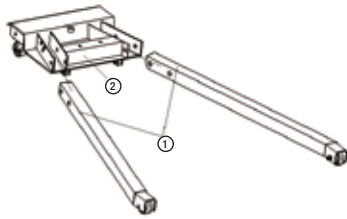

Step 4

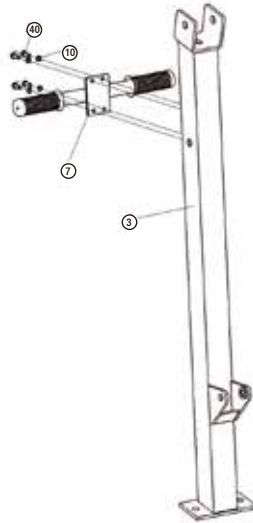

Step 3

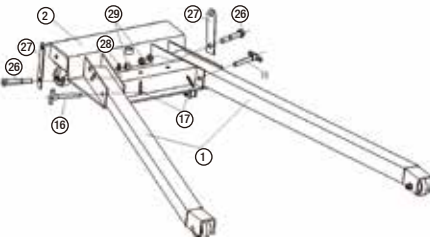

Step 5

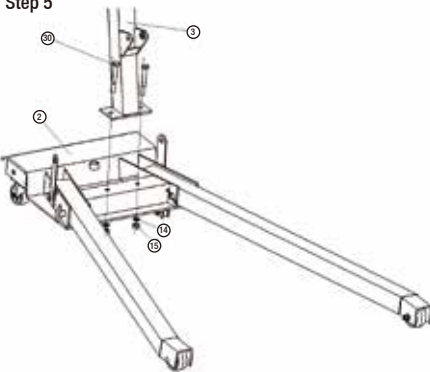

Step 6

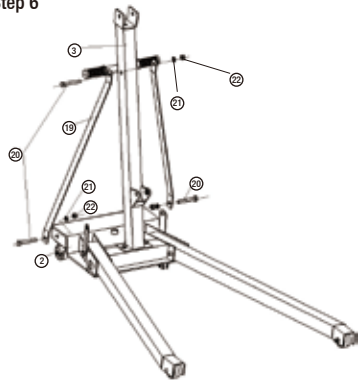

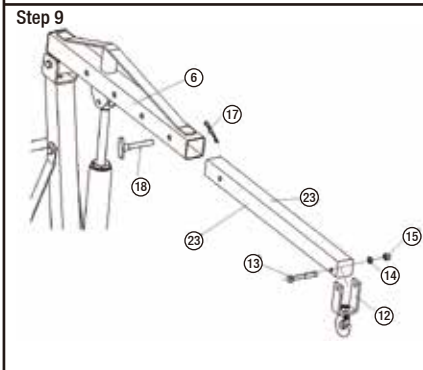
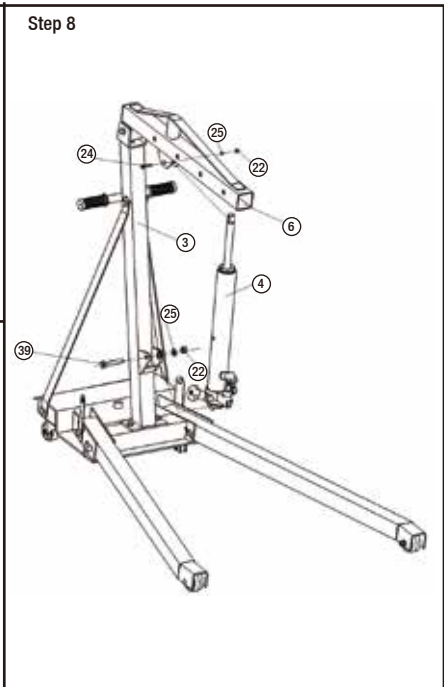
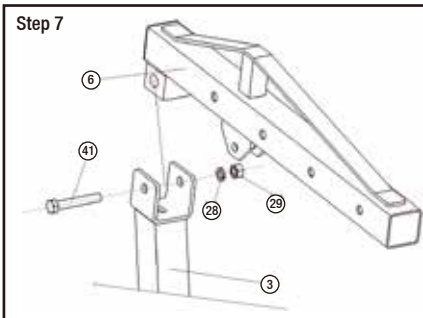

1. Attach the wheel (33) to the base (2) by bolts (34), washers (32) and nuts (31), attach the casters to the base by bolts (9), washers (10), nuts (11) and tighten all the nuts.
2. Slide the leg (1) into the groove of the base (2).
3. Attach the bracket (27) to the base (2) where the hole on the bracket line up with the hole 3 of the base, secure the legs (1) and the bracket (27) to the base by tightening the bolts (26), washers (28) and nuts (29). Lift the base a little bit to align the hole 4 of leg (1) with the hole 2 of the base, then secure them by using the frame pins (16) and splint pin (17).
4. Attach the crane handle (7) to the post (3) with bolts (40), washers (10) and tighten the bolts.
5. Attach the post (3) to the base (2) by finger tightening the bolts (30), washers (14) and nuts (15).
6. Attach the straps (19) to the base (2) by finger tightening the bolts (20), washers (21) and nuts (22). Assembly the opposite ends of the straps (19) to the post (3) by finger tightening the bolts (20), washers (21) and nuts (22). Tighten all the hardware in step 5 and step 6.
7. Attach the boom (6) to the post (3) with bolts (41), washers (28) and nuts (29). Tighten the bolts that boom can rotate freely.
8. Secure the hydraulic ram (4) in between the mounting brackets on the post (3) using the bolt (39), washer (25) and nut (22). Line up the hole in the hydraulic ram with the hole in boom (6) and secure the ram (4) with bolt (24), washer (25) and nut (22). Tighten all the nuts.
9. Slide the boom extension (23) into the boom (6) so the hole in the boom aligns with any of the four holes in the boom (6). Secure the boom extension (23) and the boom (6) together with the boom pin (18) and splint pin (17). Slide the U-bracket of the hook assembly (12) over the end of the boom extension (23), align all the holes and secure them together with bolt (13), washer (14) and nut (15).

**Note:** The boom has four different load ratings; select desired rating before use.

## OPERATION

**ATTENTION!** The workshop crane is only intended for lifting, not for bearing or transporting loads. Never overload the appliance.

**IMPORTANT!** Air in the hydraulic system can impair performance. If necessary, bleed the system by opening the relief valve fully. This is done by turning the handle clockwise, pressing the arm down and pumping rapidly several times with the pump handle.

### LIFTING

Close the relief valve by turning the handle clockwise until it resists. Do not overtighten.

### LOWERING

Open the relief valve by turning the handle anti-clockwise very slowly. You can regulate the lowering speed by turning the handle.

## MAINTENANCE AND STORAGE

**IMPORTANT!** When adding or replacing oil, always use a good grade hydraulic jack oil such as Shell Tellus 22. Avoid mixing different types of oil. Do not use brake fluid, alcohol, glycerine, detergent, motor oil or dirty oil. Improper fluid can cause serious internal damage to long ram. When adding oil, be very careful not to permit dirt or other foreign matter to get into the system.

Check ram and plunger every three months for any signs of rust or corrosion. Clean as needed and wipe with an oily cloth.

When not using the long ram, always leave the arm in the fully lowered position. **ATTENTION:** Always insert and tighten the screw and nut in the base before folding the legs up to the storage position, as there is otherwise a risk of the product tipping.

## TROUBLE SHOOTING

Problem	Cause	Solution
Will not hold load.	Dirt on valve seats.	<ol style="list-style-type: none"><li>1. Lower lifting boom. Close the release valve and remove oil filler plug.</li><li>2. Place one foot on the leg and pull up the lifting boom to its full height by hand.</li><li>3. Open the release valve to lower the lifting boom.</li><li>4. Worn seals.</li></ol>
Will not lift load. Will not lift to its full height. Pump feels unsteady under load. Pump will not lower completely.	Air block.	<ol style="list-style-type: none"><li>1. Open the release valve and remove oil filler plug.</li><li>2. Pump handle a couple of full strokes and close the release valve.</li></ol>
Pump will not lift to its full height. Pump feels unsteady under load.	The reservoir could be overfilled. Low hydraulic oil level.	Check the oil level. Remove the filler plug. Top up oil to correct level.
Pump feels unsteady under load.	The pump cup seal could be worn out.	Replace cup seal with a new one.
Will not lower completely.	Air block. Unit requires lubrication.	Release air from hydraulic pump by removing filler plug. Oil external moving parts.

# PART LIST

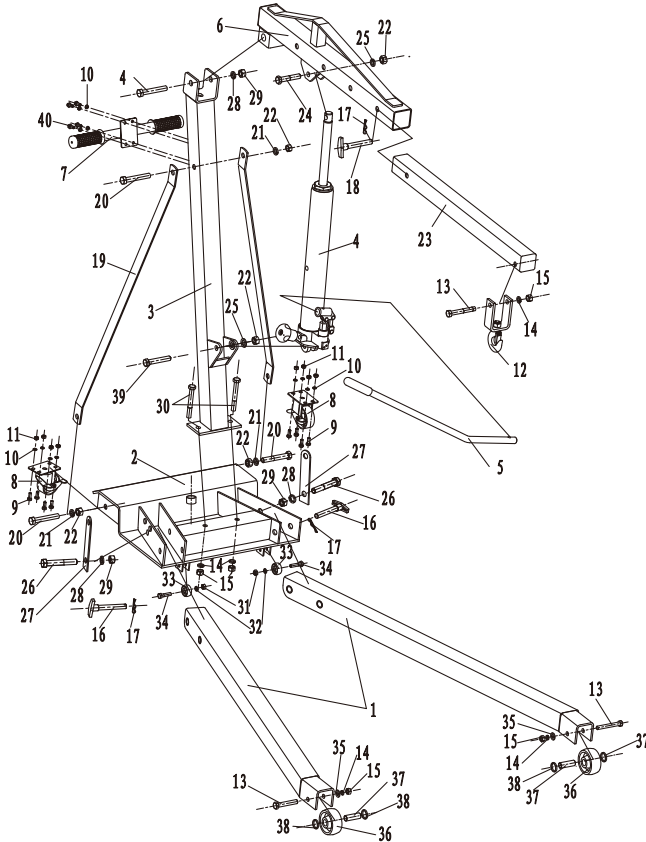

No	Description	QTY
1	Front leg	2
2	Frame base	1
3	Main support post	1
4	Hydraulic pump unit	1
5	Pump handle	1
6	Boom	1
7	Handle	1
8	Swivel caster 3"	2
9	Bolt M8x20	8
10	Spring washer 8	12
11	Nut M8	8
12	Hook assembly	1
13	Bolt M14x90	3
14	Washer 14	5

No	Description	QTY
15	Nut 14	5
16	Frame pin	2
17	Splint pin	3
18	Boom pin	1
19	Support strap	2
20	Bolt M16x100	3
21	Spring washer 16	3
22	Nut 16	5
23	Boom extension	1
24	Bolt M16x75	1
25	Washer 16	2
26	Bolt M18x110	2
27	Connector plate brackets	2
28	Spring washer 18	3

No	Description	QTY
29	Nut 18	3
30	Bolt M14x110	2
31	Nut M10	2
32	Spring washer 10	2
33	Wheel	2
34	Bolt M10x40	2
35	Washer 14	2
36	Front wheel	2
37	Bushing	2
38	Ring	4
39	Bolt M16x90	1
40	Bolt M8x10	4
41	Bolt M18x110	1

## FOLDING THE CRANE

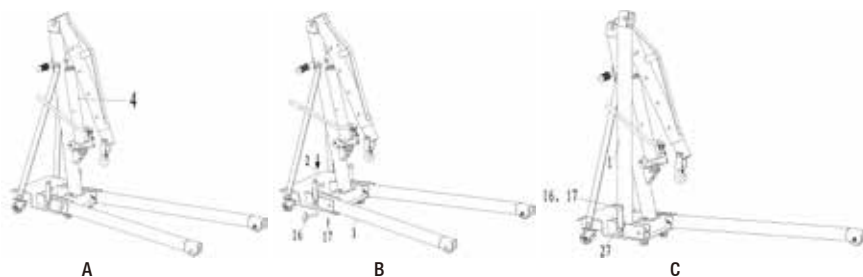

- A. Put down the hydraulic ram (4).
- B. One person step on the base (2), another person remove the frame pin (16) and splint pin (17) from the leg (1).
- C. Lift the leg (1) in the upright position. Attach the hole on the bracket (27) line up with the hole of the leg and secure it with the frame pin (16) and splint pin (17).
- D. Repeat step B and C for the other leg.

## DECLARATION OF CONFORMITY

Model: **38127**

**Foldable engine crane 2 T**

**KRAFTWERK Sàrl**, 25 rue due Stade, F-67870 Bischoffsheim

Following the provisions of Directive(s)  
Machinery Directive:

**2006/42/EC**

Bischoffsheim, 28/02/2018



Alexander Pieper  
CEO

### WARRANTY

We do not take responsibility for any damage caused by misuse or any use that is not in compliance with the safety standards described herein.

### CUSTOMER SERVICES

Contact your local importer or your specialized dealer to obtain address of our service department.

---

**FROM DATE OF PURCHASE RECEIPT  
2 YEAR GUARANTEE  
ON MATERIAL OR PRODUCTION DEFECTS**

# **KRAFTWERK®**

FAVORITE TOOLS SINCE 1979

**KRAFTWERK Europe AG**  
Mettlenbachstrasse 23  
CH-8617 Mönchaltorf  
Switzerland  
Tel. +41-44 949 40 50

**KRAFTWERK Sàrl.**  
25, rue du Stade  
F - 67870 Bischoffsheim  
France  
Tel. +33-388 48 64 50

[www.kraftwerktools.com](http://www.kraftwerktools.com)