

KRAFTWERK®

FAVORITE TOOLS SINCE 1979

AUTOMOTIVE

EN

Instruction Manual Hydropneumatic axle jack

Art. 38114



22 T



CE

Hydropneumatic axle jack

Lifting capacity	min. height	max. height	Ram lift	Screw Extend	N.W. (kg)	Working pressure
22 T	215 mm	430 mm	110 mm	105 mm	45	0.7~1.0 MPA

Assembling the 22 Ton Hydropneumatic axle jack

1. The jack comes fully assembled and easily connects to an air compressor. Figure 1 shows proper jack/air compressor connection. The air hose connecting the air compressor with the jack should be as short as possible. Installation of an air filter and oiler on the compressed is recommended. Use of a 3 horsepower or large compressor as recommended.

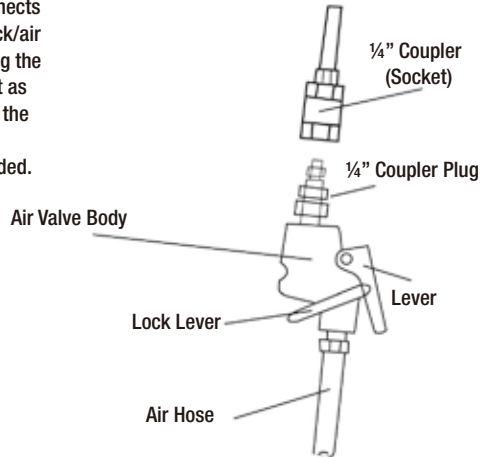

Figure 1

2. Adapter holder needs to be assembled with the handle (#5-1-2) as shown in Figure 2. Use 2 bolts, 2 nuts and 2 spring washers to complete this assembly.

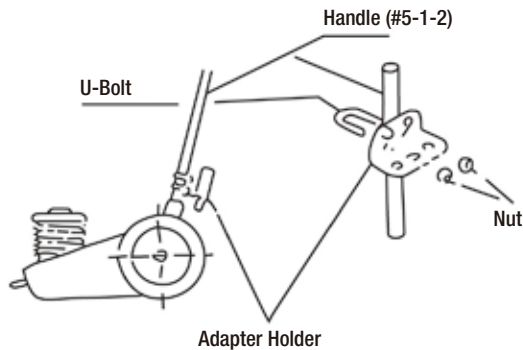

Figure 2

Operating the 22 Ton Hydropneumatic axle jack

The air compressor hose properly hooked up to the air valve assembly (#7-19), the jack is ready to be used. Test the jack before attempting to lift a vehicle.

Take the air valve assembly from the handle, and squeeze the lever to raise the piston. By Locking the lock lever in place, the piston will be raised automatically.

Stop the piston movement, release the lock lever (squeeze the lever tightly against the air valve body and moving away the lock lever) and release the lever, allowing it to return to its original position.

Lower the piston : As shown in Figure 3, slowly turn the handle knob (#5-2) counterclockwise to open the release valve. When the piston is lowered, close the handle knob by turning clockwise.

Change the handle position (see Figure pull up the lock lever (#5-14) which release the handle lock. Position the handle in one of three available positions. Make sure the handle engages in one of the three position holes, and put down the lock lever to lock handle in place.

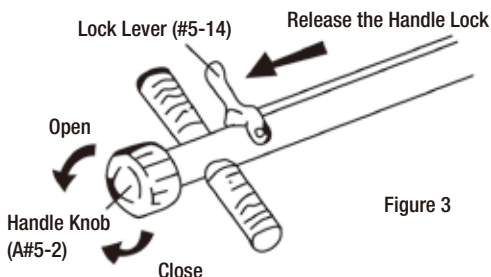

Figure 3

Handle is to be used only for moving the jack.

The jack comes with four lifting adapters. The adapters are used individually and drop into the top of the piston rod assembly. Before lifting a vehicle, inspect the vehicle's contact point which will come in contact with the jack adapter. Pick an adapter which has the right size and shape to match this contact point.

Always make sure the contact point and the adapter are clean and grease free before attempting to lift the vehicle. Make sure the adapter is positioned directly under the contact point before attempting to jack up the vehicle.

Maintenance

Note: The jack's safety valve has been calibrated by the manufacturer. Never attempt to disassemble the safety valve.

As shown in Figure 4, use a good quality hydraulic tool oil once twice per month to lubricate the air valve.

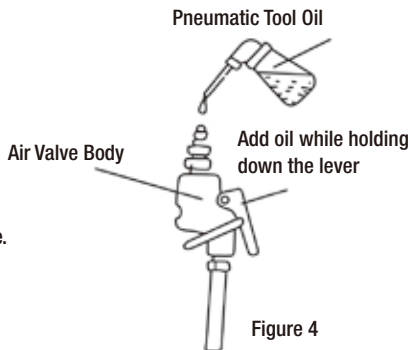

Figure 4

Oil in the oil tank should be replaced once per year, or more often with heavy use. Use only good quality hydraulic tool oil. See Figure 5. To access to the oil tank, remove the screw.

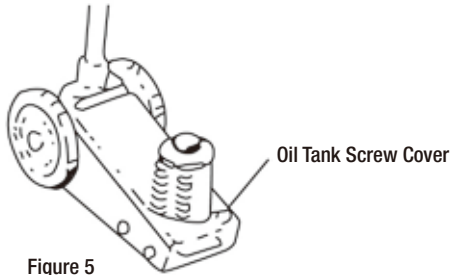

Figure 5

Note : Occasionally, air bubbles can become trapped inside the hydraulic system thereby reducing the efficiency of the jack. Purge air from the hydraulic system as needed by following the below listed steps (see Figure 6):

1. Remove the upper cover (#6-12).
2. Loosen the bolt one half a turn.
3. Close the release valve.
4. Operate the air pump while repeatedly tightening and loosening the bolt.
5. Tighten the bolt when the piston begins to rise. Verify that the piston can rise to the maximum height position.

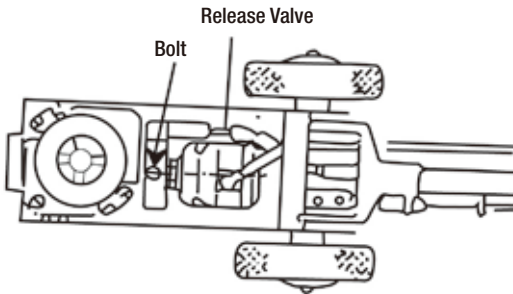
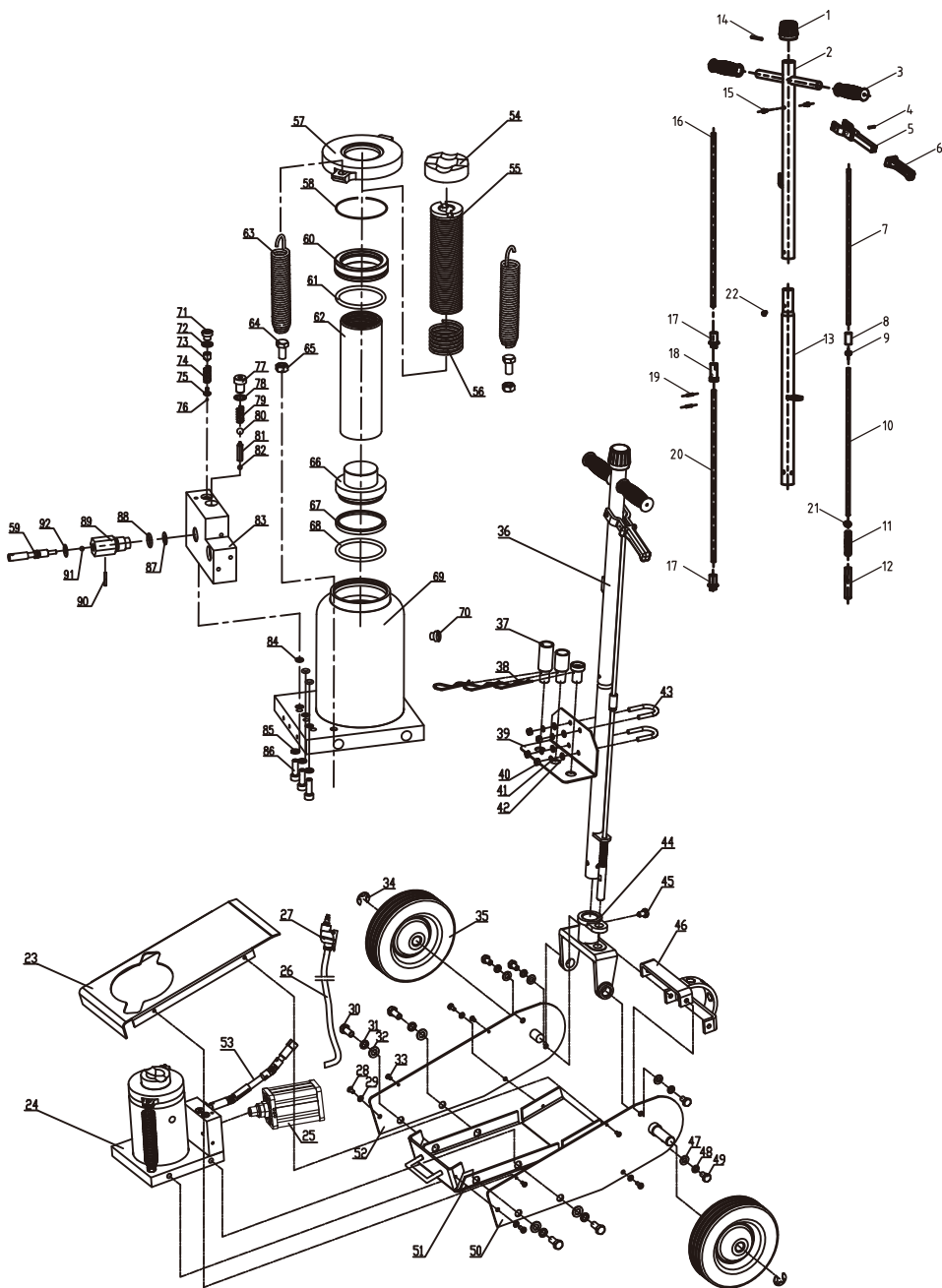

Figure 6



No.	Description	QTY.	No.	Description	QTY.
1	Knob	1	47	Washer 10	4
2	Upper handle	1	48	Washer 10	4
3	Rubber handle cover	2	49	Bolt	4
4	Pin	1	50	Left frame	1
5	Lock lever	1	51	Lower cover	1
6	Cover for lock lever	1	52	Right frame	1
7	Upper stopper	1	53	Release valve assembly	1
8	Upper connect head	1	54	Nut	1
9	Nut M8	1	55	Screw	1
10	Lower stopper	1	56	Bushing	1
11	Spring	1	57	Cover	1
12	Lower connect head	1	58	Snap ring	1
13	Lower handle	1	59	Release Valve Rod	1
14	Pin	1	60	Plunger ring	2
15	Bolt M5	2	61	O-Ring	1
16	Connection rod	1	62	Piston rod	1
17	Connect	2	63	Spring	2
18	Connect	1	64	Bolt M10x20	2
19	Pin	2	65	Nut M10	2
20	Connection rod	1	66	Piston	1
21	Washer 8	1	67	Back-up ring	1
22	Bolt M5x10	1	68	Y-Ring	1
23	Upper cover	1	69	Base assembly	1
24	Hydraulic unit assembly	1	70	Oil Plug	1
25	Air pump unit	1	71	Safety valve cap	1
26	Air hose	1	72	O-Ring	1
27	On/off switch	1	73	Safety valve	1
28	Bolt	4	74	Spring	1
29	Washer 6	4	75	Spring seat	1
30	Bolt	4	76	Ball 3	1
31	Spring Washer12	4	77	Bolt M12 x 16	1
32	Washer12	4	78	O-Ring	1
33	Bolt	4	79	Spring	1
34	Snap Ring	2	80	Ball 9	1
35	Wheel	2	81	Spring	1
36	Handle assembly	1	82	Ball 6	1
37	Adaptor set	3	83	Valve block	1
38	Spring clips	3	84	O-Ring	3
39	Adaptor holder	1	85	Spring washer	3
40	Nut	4	86	Bolt M8 x 25	3
41	Washer 8	4	87	Washer	1
42	Washer 8	4	88	O-Ring	1
43	U-Bolt	2	89	Release Valve	1
44	Socket	1	90	Screw	1
45	Bolt	1	91	Ball 6	1
46	Socket bracket	1	92	O-Ring	1

DECLARATION OF CONFORMITY

Model: **38114**

Hydropneumatic axle jack 22 t

KRAFTWERK Sàrl, 25 rue due Stade, F-67870 Bischofsheim

Declares under sole responsibility that the product to which this declaration relates is in conformity with the following standard(s) or other normative document(s):

EN 1494: 2000+A1/2008

EN ISO 12100: 2010

Following the provisions of Directive(s)

Machinery Directive:

2006/42/EC

Bischofsheim, 28/11/2018



Alexander Pieper
CEO

WARRANTY

We do not take responsibility for any damage caused by misuse or any use that is not in compliance with the safety standards described herein.

CUSTOMER SERVICES

Contact your local importer or your specialized dealer to obtain address of our service department.

**FROM DATE OF PURCHASE RECEIPT
2 YEAR GUARANTEE
ON MATERIAL OR PRODUCTION DEFECTS**

KRAFTWERK®

FAVORITE TOOLS SINCE 1979

KRAFTWERK Europe AG
Mettlenbachstrasse 23
CH-8617 Mönchaltorf
Switzerland
Tel. +41-44 949 40 50

KRAFTWERK Sàrl.
25, rue du Stade
F - 67870 Bischoffsheim
France
Tel. +33-388 48 64 50

www.kraftwerktools.com