

KRAFTWERK®

FAVORITE TOOLS SINCE 1979

Instruction Manual

Cordless bit driver 7.2 V

Art. 32106

EN

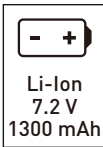

WARNING:

DO NOT attempt to operate the tool until you have read and understood all instructions and safety rules contained in this manual. Failure to comply may result in accidents involving fire, electric shock, or serious personal injury. Save this owner's manual for future reference and review it frequently for safe operation.



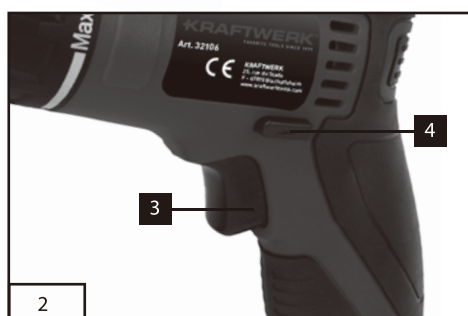
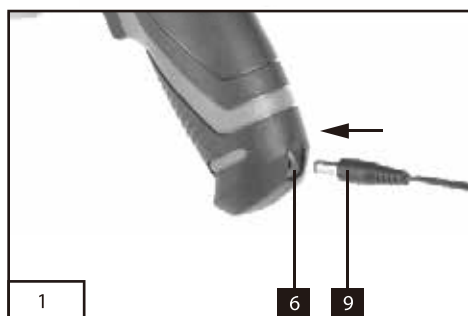
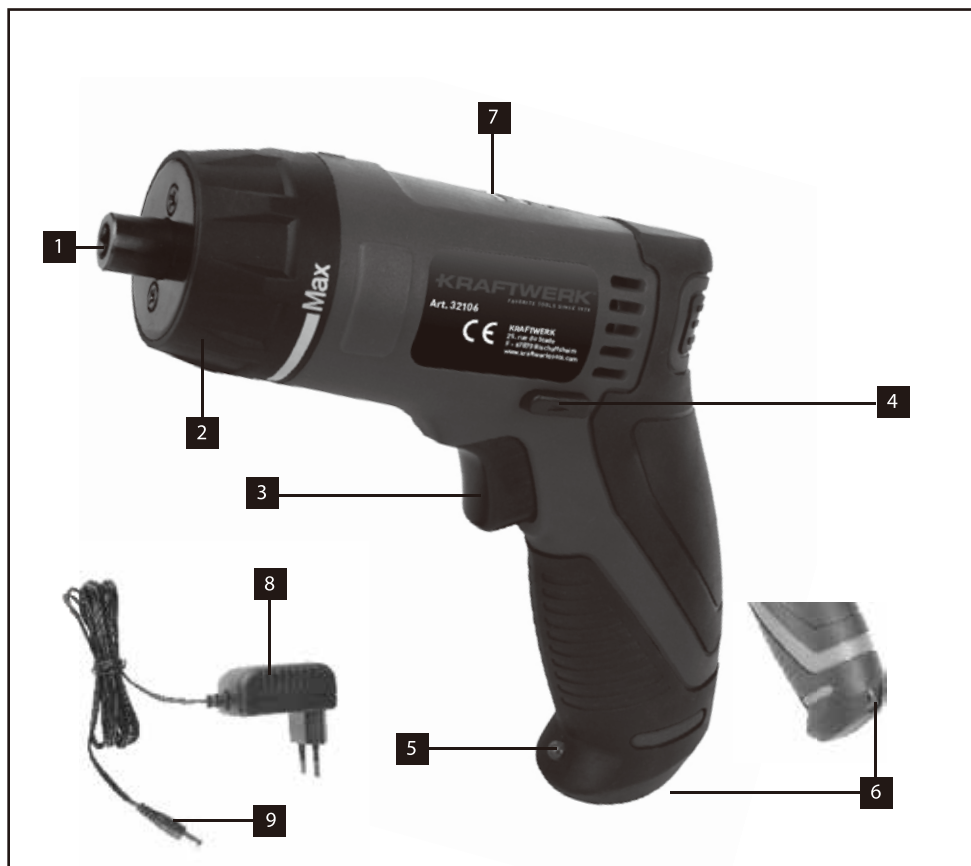

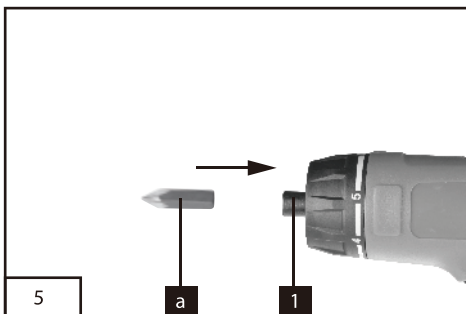
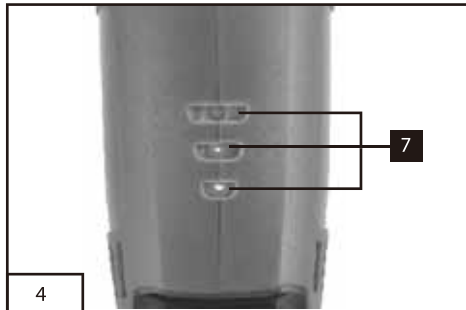

1. Proper usage

The machine is intended for driving in and loosening screws as well as for drilling in wood, metal, ceramic and plastic.

2. Safety instructions and warnings

The equipment complies with the safety regulations required for electrical equipment.

Read through the instructions for use before starting up the equipment.

Improper use can lead to personal injury and property damage. Persons, who are not familiar with the instructions, may not operate the equipment.

Keep the instructions for use in safe custody.

Children and youths are not permitted to operate the equipment.

3. General Power Tool Safety Warnings

WARNING Read all safety warnings and all instructions. Failure to follow the warnings and instructions may result in electric shock, fire and/or serious injury.

Save all warnings and instructions for future reference.

The term "power tool" in the warnings refers to your mains-operated (corded) power tool or battery-operated (cordless) power tool.

1) Work area safety

a) Keep work area clean and well lit. Cluttered or dark areas invite accidents.

b) Do not operate power tools in explosive atmospheres, such as in the presence of flammable liquids, gases or dust. Power tools

create sparks which may ignite the dust or fumes.

c) Keep children and bystanders away while operating a power tool. Distractions can cause you to lose control.

2) Electrical safety

a) Power tool plugs must match the outlet. Never modify the plug in any way. Do not use any adapter plugs with earthed (grounded) power tools. Unmodified plugs and matching outlets will reduce risk of electric shock.

b) Avoid body contact with earthed or grounded surfaces, such as pipes, radiators, ranges and refrigerators. There is an increased risk of electric shock if your body is earthed or grounded.

c) Do not expose power tools to rain or wet conditions. Water entering a power tool will increase the risk of electric shock.

d) Do not abuse the cord. Never use the cord for carrying, pulling or unplugging the power tool. Keep cord away from heat, oil, sharp edges and moving parts. Damaged or entangled cords increase the risk of electric shock.

e) When operating a power tool outdoors, use an extension cord suitable for outdoor use. Use of a cord suitable for outdoor use reduces the risk of electric shock.

f) If operating a power tool in a damp location is unavoidable, use a residual current device (RCD) protected supply. Use of an RCD reduces the risk of electric shock.

3) Personal safety

a) Stay alert, watch what you are doing and use common sense when operating a power tool. Do not use a power tool while you are tired or under the influence of drugs, alcohol

or medication. A moment of inattention while operating power tools may result in serious personal injury.

b) Use personal protective equipment. Always wear eye protection. Protective equipment such as dust mask, non-skid safety shoes, hard hat, or hearing protection used for appropriate conditions will reduce personal injuries.

c) Prevent unintentional starting. Ensure the switch is in the off-position before connecting to power source and/or battery pack, picking up or carrying the tool. Carrying power tools with your finger on the switch or energising power tools that have the switch on invites accidents.

d) Remove any adjusting key or wrench before turning the power tool on. A wrench or a key left attached to a rotating part of the power tool may result in personal injury.

e) Do not overreach. Keep proper footing and balance at all times. This enables better control of the power tool in unexpected situations.

f) Dress properly. Do not wear loose clothing or jewellery. Keep your hair, clothing and gloves away from moving parts. Loose clothes, jewellery or long hair can be caught in moving parts.

g) If devices are provided for the connection of dust extraction and collection facilities, ensure these are connected and properly used. Use of dust collection can reduce dust-related hazards.

4) Power tool use and care

a) Do not force the power tool. Use the correct power tool for your application. The correct power tool will do the job better and safer at the rate for which it was designed.

b) Do not use the power tool if the switch does not turn it on and off. Any power tool that cannot be controlled with the switch is dangerous and must be repaired.

c) Disconnect the plug from the power source and/or the battery pack from the power tool before making any adjustments, changing accessories, or storing power tools. Such preventive safety measures reduce the risk of starting the power tool accidentally.

d) Store idle power tools out of the reach of children and do not allow persons unfamiliar with the power tool or these instructions to operate the power tool. Power tools are dangerous in the hands of untrained users.

e) Maintain power tools. Check for misalignment or binding of moving parts, breakage of parts and any other condition that may affect the power tool's operation. If damaged, have the power tool repaired before use. Many accidents are caused by poorly maintained power tools.

f) Use the power tool, accessories and tool bits etc. in accordance with these instructions, taking into account the working conditions and the work to be performed. Use of the power tool for operations different from those intended could result in a hazardous situation.

5) Battery tool use and care

a) Recharge only with the charger specified by the manufacturer. A charger that is suitable for one type of battery pack may create a risk of fire when used with another battery pack.

b) Use power tools only with specifically designated battery packs. Use of any other battery packs may create a risk of injury and fire.

c) When battery pack is not in use, keep it away from other metal objects, like paper clips, coins, keys, nails, screws or other small metal objects, that can make a connection from one terminal to another. Shorting the battery terminals together may cause burns or a fire.

d) Under abusive conditions, liquid may be ejected from the battery; avoid contact. If contact accidentally occurs, flush with water. If liquid contacts eyes, additionally seek medical help. Liquid ejected from the battery may cause irritation or burns.

6) Service

a) Have your power tool serviced by a qualified repair person using only identical replacement parts. This will ensure that the safety of the power tool is maintained.

4. Special safety instructions

• **Hold power tool by insulated gripping surfaces, when performing an operation where the cutting accessory or fastener may contact hidden wiring.** Cutting accessory and fasteners contacting a “live” wire may make exposed metal parts of the power tool “live” and could give the operator an electric shock.

• **Use appropriate detectors to determine if utility lines are hidden in the work area or call the local utility company for assistance. Contact with electric lines can lead to fire and electric shock. Damaging a gas line can lead to explosion.** Penetrating a water line causes property damage or may cause an electric shock.

• **Switch off the power tool immediately when the tool insert jams. Be prepared for high reaction torque that can cause kickback.**

The tool insert jams when:

- the power tool is subject to overload or
- it becomes wedged in the workpiece.

• **Hold the machine with a firm grip.** High reaction torque can briefly occur while driving in and loosening screws.

• **Secure the workpiece.** A workpiece clamped with clamping devices or in a vice is held more secure than by hand.

• **Keep your workplace clean. Blends of materials are particularly dangerous.** Dust from light alloys can burn or explode.

• **Always wait until the machine has come to a complete stop before placing it down.** The tool insert can jam and lead to loss of control over the power tool.

• **Do not open the battery. Danger of shortcircuiting.** Protect the battery against heat, e. g., also against continuous sun irradiation and fire. There is danger of explosion.

• **In case of damage and improper use of the battery, vapours may be emitted.** Provide for fresh air and seek medical help in case of complaints. The vapours can irritate the respiratory system.

• **When the battery is defective, liquid can escape and come into contact with adjacent components.** Check any parts concerned. Clean such parts or replace them, if required.

5. Description of symbols

Pay attention to all the signs and symbols shown in these instructions and on your tool. Make a note of these signs and symbols. If you interpret the signs and symbols correctly, your work with the machine will be safer and better.



Important.



Read the instructions for use before starting the machine.



Wear safety goggles.



Wear ear protection.



Wear good quality, strong gloves.



Always use breathing apparatus when machining materials which generate dust.



End of life machines contain valuable materials and therefore they should not be placed in household waste.

We would ask you to play your part in protecting resources and help protect the environment by returning this machine to a return point (if one is available) when it reaches the end of its life.

6. Layout

1. Bit chuck
2. Torque selector
3. On/Off switch
4. Clockwise/Counter-clockwise selector switch
5. Lamp
6. Charging socket
7. Battery capacity indicator
8. Battery charger
9. Charging cable

7. Before starting the equipment

Be sure to read the following information before you use your cordless screwdriver for the first time:

1. Charge the battery pack with the charger supplied. An empty battery pack requires a charging period of approximately 1 hour.
2. Only ever use sharp drill bits and screwdriver bits which are suitable for the purpose and in faultless condition.
3. Always check for concealed electric cables and gas and water pipes when drilling and screwing in walls.

8. Operation

8.1 Charging the battery (Fig. 1)

The battery is protected from exhaustive discharge.

An integrated protective circuit automatically switches off the equipment when the battery is flat. In this case the bit chuck will cease to turn.

Warning! Do not press the ON/OFF switch any more if the protective circuit has actuated. This may damage the battery.

1. Check that your mains voltage is the same as that marked on the rating plate of the battery charger. Plug the battery charger in the plug socket and connect the charging cable (9) to the charging socket (6).

2. LED indications (7):
red LED illuminate: beginning charging process
yellow and red LED illuminate: battery is partly charged
all LEDs illuminate: battery is fully charged.

If the battery pack fails to charge, please check

- whether there is voltage at the socket-outlet
- and check for proper contact with the charging contacts in the battery charger.

If the battery still fails to charge, send

- the battery charger
- and the screwdriver

to our customer services department.

Timely recharging of the battery pack will help it serve you well for a long time. You must recharge the battery pack when you notice that the power of the screwdriver drops.

Never allow the battery pack to become fully discharged. This will cause it to develop a defect.

8.2 Changeover switch (Fig. 2/Item 4)

The slide switch above the ON/OFF switch is for setting the direction of rotation of the cordless screwdriver and for preventing the cordless screwdriver from being switched on inadvertently.

You can select between clockwise and counterclockwise rotation. Change the direction of rotation only when the equipment is at a

standstill. If you fail to observe this point, the gearing may become damaged. When the slide switch is in the middle position, the ON/OFF switch is blocked.

8.3 ON/OFF switch (Fig. 2 / Item 3)

Press the On/Off switch to switch the cordless screwdriver on. Release the ON/OFF switch to switch off the tool.

8.4 LED lamp

The LED lamp (5) can be used in poor lighting conditions to illuminate the area where you want to screw.

8.5 Torque setting (Fig. 3)

The cordless screwdriver is fitted with a mechanical torque selector.

The torque for a specific size of screw is selected with the torque selector (2). The correct torque depends on several factors:

- on the type and hardness of material in question
- on the type and length screws used
- on the requirements needing to be met by the screwed joint.

The clutch disengages with a grating sound to indicate when the set torque is reached.

8.6 Battery capacity indicator (Fig. 4)

The battery capacity indicator (7) indicates the charge state of the battery on 3 colored LEDs.

All LEDs illuminate:

The battery is fully charged.

The yellow and red LED illuminate:

The battery has an adequate remaining charge.

Red LED:

The battery is empty, recharge the battery.

8.7 Changing the tool (Fig. 5)

Important! Set the changeover switch to its centre position whenever you carry out any work (for example changing the tool, maintenance work, etc.) on the cordless screwdriver.

- Insert the bit (a) into the bit chuck (1).
- Check that it is secure by attempting to pull the tool apart again.

8.8 Screwdriving

We recommend using self-centering screws (e.g. Torx screws, recessed head screws) designed for reliable working. Be sure to use a bit that matches the screw in shape and size. Set the torque, as described elsewhere in these operating instructions, to suit the size of screw.

9. Technical data

Motor power supply:	7,2 V d.c./1,3 Ah Li-ion
Idle speed:	0-230 min ⁻¹
Clockwise/Counter-clockwise:	Yes
Bit chuck:	6,35 mm (1/4")
Torque settings:	5+1
Max. torque:	10 Nm
Charge voltage for rechargeable battery:	9,5 V DC
Charge current for rechargeable battery:	500 mA
Battery charger supply voltage:	100-240 V~ / 50/60 Hz
Charging time:	3 hours
Weight:	0,57 kg

Sound and vibration

Sound and vibration values were measured in

accordance with EN 60745.

L_{pA} sound pressure level	67 dB(A)
K_{pA} uncertainty	3 dB
L_{WA} sound power level	78 dB(A)
K_{WA} uncertainty	3 dB

Wear ear-muffs.

The impact of noise can cause damage to hearing.

Total vibration values (vector sum of three directions) determined in accordance with EN 60745.

Screwing without hammer action

Vibration emission value $a_{rh} = 0,729 \text{ m/s}^2$
K uncertainty = 1,5 m/s^2



Important!

The vibration value changes according to the area of application of the electric tool and may exceed the specified value in exceptional circumstances.

10. Cleaning and maintenance

Always pull out the mains power plug before starting any cleaning work.

10.1 Cleaning

- Keep all safety devices, air vents and the motor housing free of dirt and dust as far as possible. Wipe the equipment with a clean cloth or blow it with compressed air at low pressure.

- We recommend that you clean the device immediately each time you have finished using it.

- Clean the equipment regularly with a moist cloth and some soft soap. Do not use cleaning agents or solvents; these could attack the plastic parts of the equipment. Ensure that no water can seep into the device.

10.2 Maintenance

There are no parts inside the equipment which require additional maintenance.

11. Repairs

Only use accessories and spare parts recommended by the manufacturer.

If the equipment should fail some day in spite of our quality controls and your maintenance, only have it repaired by an authorized electrician.

If the supply cord of the appliance is damaged, this has to be done by the manufacturer or his agent or electrician in order to avoid a safety hazard.

12. Environmental protection



End of life electrical equipment must not be placed in household waste. Please take it to a return point. Find out about your nearest return point from your council or sales outlet.

DECLARATION OF CONFORMITY

Model: 32106
LI-ION 60 MIN. FAST CHARGER 18 V

KRAFTWERK Sàrl, 25 rue due Stade, F-67870 Bischoffsheim

Declares under sole responsibility that the product to which this declaration relates is in conformity with the following standard(s) or other normative document(s):

EN 55014-1: 2006+A1/2009+A2/2011
EN 55014-2: 1997+A1/2001+A2/2008
EN 60745-1: 2009+A11/2010
EN 60745-2-2: 2010
EN 60335-1: 2012+A11/2014
EN 60335-2-29: 2004+A2/2010
EN 62233: 2008

Following the provisions of Directive(s)
Machinery Directive:

2014/30/EU
2006/42/EC
2014/35/EU



Alexander Pieper
CEO

Bischoffsheim, 06/09/2017

WARRANTY

We do not take responsibility for any damage caused by misuse or any use that is not in compliance with the safety standards described herein.

CUSTOMER SERVICES

Contact your local importer or your specialized dealer to obtain address of our service department.

**FROM DATE OF PURCHASE RECEIPT
2 YEAR GUARANTEE
ON MATERIAL OR PRODUCTION DEFECTS**

KRAFTWERK®

FAVORITE TOOLS SINCE 1979

KRAFTWERK Europe AG
Mettlenbachstrasse 23
CH-8617 Mönchaltorf
Switzerland
Tel. +41-44 949 40 50

KRAFTWERK Sàrl.
25, rue du Stade
F - 67870 Bischoffsheim
France
Tel. +33-388 48 64 50

www.kraftwerktools.com