



KRAFTWERK®

quality tools

Using-Instructions

**LI-ION CORDLESS IMPACT WRENCH 18 V 1/2" 850 Nm
WITH DIGITAL CLUTCH
LI-ION 60 MIN. FAST CHARGER 18 V**

2

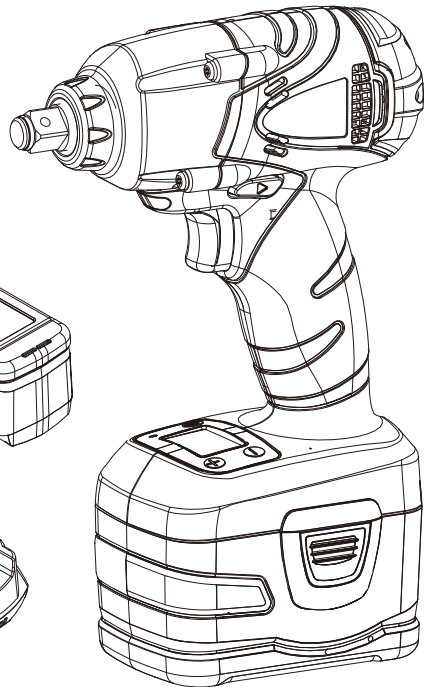
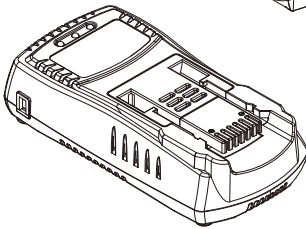
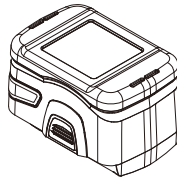

⚠ WARNING:
DO NOT attempt to operate the tool until you have read and understood all instructions and safety rules contained in this manual. Failure to comply may result in accidents involving fire, electric shock, or serious personal injury. Save this owner's manual for future reference and review it frequently for safe operation.

Art. 32103



Please read these instructions carefully to ensure the safe and effective use of this tool.

Download Bedienungsanleitung / Téléchargement du mode d'emploi / Instructions download
Descarga de la instrucción de uso / Download de instruções de operação / Download del manuale



www.KRAFTWERKtools.com

GENERAL SAFETY RULES

WARNING! READ AND UNDERSTAND ALL INSTRUCTIONS.

Read all instructions Failure to follow all instructions listed below may result in electric shock, fire and/or serious injury. The term "power tool" in all of the warnings listed below refers to your mains-operated (corded) power tool or battery-operated (cordless) power tool.

SAVE THESE INSTRUCTIONS

WORK AREA

1. **Keep work area clean and well lit.** Cluttered and dark areas invite accidents.
2. **Do not operate power tools in explosive atmospheres, such as in the presence of flammable liquids, gases or dust.** Power tools create sparks which may ignite the dust or fumes.
3. **Keep children and bystanders away while operating a power tool.** Distractions can cause you to lose control.

ELECTRICAL SAFETY

1. **A battery operated tool with integral batteries or a separate battery pack must be recharged only with the specified charger for the battery.** A charger that may be suitable for one type of battery may create a risk of fire when used with another battery.
2. **Use battery powered operated tool only with specifically designated battery pack.** Use of any other batteries may create a risk of fire.
3. **Avoid body contact with earthed or grounded surfaces such as pipes, radiators, ranges and refrigerators.** There is an increased risk of electric shock if your body is earthed or grounded.
4. **Do not expose power tool to rain or wet conditions.** Water entering a power tool will increase the risk of electric shock.
5. **When operating a power tool outdoors, use an extension cord suitable for outdoor use.** Use of a cord suitable for outdoor use reduces the risk of electric shock.

PERSONAL SAFETY

6. **Stay alert, watch what you are doing and use common sense when operating a power tool. Do not use a power tool while you are tired or under the influence of drugs, alcohol or medication.** A moment of inattention while operating power tools may result in serious personal injury.
7. **Use personal protective equipment. Always wear eye protection.** Protective equipment such as dust mask, non-skid safety shoes, hard hat, or hearing protection used for appropriate conditions will reduce personal injuries.
8. **Avoid accidental starting.** Ensure the switch is in the off-position before plugging in. Carrying power tools with your finger on the switch or plugging in power tools that have the switch on invites accidents.
9. **Remove any adjusting key or wrench before turning the power tool on.** A wrench or a key left attached to a rotating part of the power tool may result in personal injury.
10. **Do not overreach. Keep proper footing and balance at all times.** This enables better control of the power tool in unexpected situations.
11. **Dress properly. Do not wear loose clothing or jewellery. Keep your hair, clothing and gloves away from moving parts.** Loose clothes, jewellery or long hair can be caught in moving parts.
12. **If devices are provided for the connection of dust extraction and collection facilities, ensure these are connected and properly used.** Use of dust collection can reduce dust-related hazards.

TOOL USE AND CARE

13. **Do not force the power tool. Use the correct power tool for your application.** The correct power tool will do the job better and safer at the rate for which it was designed.
14. **Do not use the power tool if the switch does not turn it on and off.** Any power tool that cannot be controlled with the switch is dangerous and must be repaired.

15. **Disconnect the plug from the power source and/or the battery pack from the power tool before making any adjustments, changing accessories, or storing power tools.** Such preventive safety measures reduce the risk of starting the power tool accidentally.
16. **Store idle power tools out of the reach of children and do not allow persons unfamiliar with the power tool or these instructions to operate the power tool.** Power tools are dangerous in the hands of untrained users.
17. **Maintain power tools.** Check for misalignment or binding of moving parts, breakage of parts and any other condition that may affect the power tool's operation. If damaged, have the power tool repaired before use. Many accidents are caused by poorly maintained power tools.
18. **Keep cutting tools sharp and clean.** Properly maintained cutting tools with sharp cutting edges are less likely to bind and are easier to control.
19. **Use the power tool, accessories and tool bits etc. in accordance with these instructions, taking into account the working conditions and the work to be performed.** Use of the power tool for operations different from those intended could result in a hazardous situation.

BATTERY TOOL USE AND CARE

1. **Ensure the switch is in the off position before inserting battery pack.** Inserting the battery pack into power tools that have the switch on invites accidents.
2. **Recharge only with the charger specified by the manufacturer.** A charger that is suitable for one type of battery pack may create a risk of fire when used with another battery pack.
3. **Use power tools only with specifically designated battery packs.** Use of any other battery packs may create a risk of injury and fire.
4. **When battery pack is not in use, keep it away from other metal objects like paper clips, coins, keys, nails, screws, or other small metal objects that can make a connection from one terminal to another.** Shorting the battery terminals together may cause burns or a fire.
5. **Under abusive conditions, liquid may be ejected from the battery; avoid contact.** If contact accidentally occurs, flush with water. If liquid contacts eyes, additionally seek medical help. Liquid ejected from the battery may cause irritation or burns.

SERVICE

6. **Have your power tool serviced by a qualified repair person using only identical replacement parts.** This will ensure that the safety of the power tool is maintained.
7. **Tool service must be performed only by qualified repair personnel.** Service or maintenance performed by unqualified personnel may result in a risk of injury.
8. **When servicing a tool, use only identical replacement parts.** Follow instructions in the Maintenance section of this manual. Use of unauthorized parts or failure to follow Maintenance Instructions may create a risk of shock or injury.

SPECIFIC SAFETY RULES AND SYMBOLS

1. **Hold tool by insulated gripping surfaces when performing an operation where the cutting tool may contact hidden wiring.** Contact with 'live' wire will also make exposed metal parts of the tool 'live' and shock the operator.
2. **Be aware that this tool is always in an operating condition, because it does not have to be plugged into an electrical outlet. Always set the trigger switch to the locked OFF position when installing or removing the battery pack or bits.**
3. **Do not use bits or sockets larger than those recommended.** Large bits may overload the driver and damage the motor and gears.
4. **Do not use if chuck jaws or other parts are cracked or worn.**
5. **Never change direction of rotation until motor has completely stopped.**
6. **Never hold work in your hand, lap, or against other parts of your body when driving.**
7. **Do not use driver as a router or try to elongate or enlarge holes by twisting the driver bit.** Driver bits may break and cause injury.
8. **Keep hands away from rotating parts.**

- 9. **Keep driver bit clear of yourself and all objects while installing and removing bit.**
- 10. **Some wood contains preservatives which can be toxic.** Take extra care to prevent inhalation and skin contact when working with these materials. Request, and follow, all safety information available from your material supplier.
- 11. **The label on your tool may include the following symbols.** The symbols and their definitions are as follows:

V	volts
kg	kilograms
	direct current
... /min	revolutions or reciprocation per minute

FUNCTIONAL DESCRIPTION

SPECIFICATION

Model Number	32103
Voltage	18 V
Drive	1/2" Square
Overall length	174.4 mm (6-7/8")
Max. Torque	400 Nm (300 ft-lbs)
Reverse Torque	640 Nm (480 ft-lbs)
Breakaway torque	850 Nm (638 ft-lbs)
No Load Speed	0-2000 /min
Impacts per Minute	0-3000 ipm
Control Torque Range	80-260 Nm (60-190 ft-lbs)
Tool Weight	1.93 kg (4.24 lbs)

Operating Status Indicator

▶ Reached	Green LED Lighting
▶ LV/OT	Red LED Lighting
Auto Shut-Off	After 1 Minute of No Use
Battery Indication	5 Stages

Hand-Arm Vibration Level (Arithmetic total average)

Load:

"Uncertainty K = 1.5 m/s²"

Warning: "The vibration emission during actual use of the power tool can differ from the declared total value depending on the ways in which the tool is used" 15.74 m/s²

Summary (Noise)

Load:

(a) A-weighted emission sound pressure level

LPA = 95.9 dB(A)

(b) A-weighted sound power level

LWA = 106.9 dB(A)

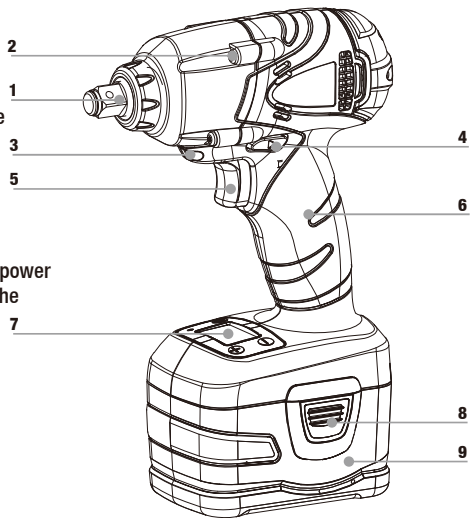

- 1. 1/2" Anvil
- 2. Aluminum Gearbox Housing
- 3. Built-in LED light
- 4. Forward / Reverse Control Button
- 5. Variable Speed Switch (VSR)
- 6. Anti-slip Soft Grip
- 7. Digital Clutch
- 8. Battery Pack Release Button
- 9. Battery Pack

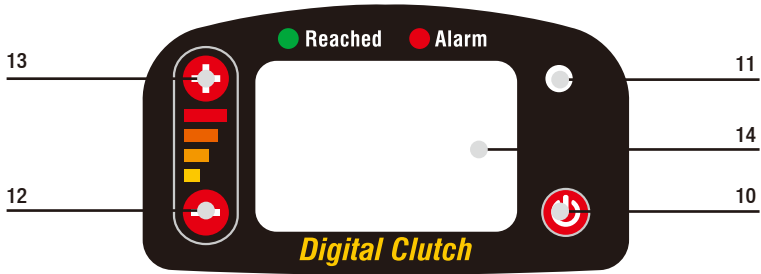

LCD PANEL COMPONENTS

- | | |
|--------------------------------|----------------------------------|
| 10. Power On/Off | 11. LED Indication Light |
| 12. Reduce Torque Range Button | 13. Increase Torque Range Button |
| 14. LCD Display | |

LOW VOLTAGE AND OVER TEMPERATURE PROTECTIVE CIRCUIT

- When the battery voltage is under 14.4 V, the power will cut off. At the same time, LED indication light turn red and the LCD display will show “LV”.
- When the power tool is operated on “MAX” stage for a certain period of time and the temperature is over 140°F (60°C), the power will cut off. At the same time, LED indication light turns red and the LCD display will show “OT”.



Max stage of torque



Low Voltage



Over Temperature

LED INDICATION LIGHT SIGNAL & MESSAGE ON LCD DISPLAY DURING OPERATION

- During Operation: LED indication light is blinking green and the LCD display will show the setting stage of digital clutch.
- Designated Torque Reached: LED indication light remains green and the LCD display will show the setting stage of digital clutch.
- Low Voltage: Power will cut off, LED indication light turns red and the LCD display will show “LV”.
- Over Temperature: Power will cut off, LED indication light turns red and the LCD display will show “OT”.

AUXILIARY FUNCTIONS

- There are 5 torque clutch stage settings.
- Every stage shows the battery capacity.
- When pressing the VSR switch the built-in LED light will turn on as well.



REFERENCE TORQUE AVERAGE VALUES OF EACH TORQUE CLUTCH STAGE

Stage	Tightening	Loosening
01	80 Nm (60 ft-lbs)	
02	110 Nm (80 ft-lbs)	
03	150 Nm (110 ft-lbs)	
04	200 Nm (150 ft-lbs)	
05	260 Nm (190 ft-lbs)	
Max	400 Nm (300 ft-lbs)	850 Nm (638 ft-lbs) 640 Nm (480 ft-lbs)
NOTE: Always check torque with a torque wrench.		

MEMORY FUNCTION

The last choosed torque clutch stage will be memorized and will appear again when you turn on the LCD panel.

VARIABLE SPEED SWITCH

The variable speed switch provides safety feature to the user for screw driving.

To turn the tool on, squeeze the trigger switch. To turn the tool off, release the trigger switch (see Fig. 1A).

Your tool is equipped with a brake. The chuck will stop as soon as the trigger switch is fully released. The variable speed switch enables you to select the best speed for a particular application. The farther you squeeze the trigger, the faster the tool will operate.

Use lower speeds for starting holes without a center punch, drilling metals or plastic, driving screws and drilling ceramics, or in any application requiring high torque. Higher speeds are better drilling in wood, wood compositions and for using abrasive and polishing accessories. For maximum tool life, use variable speed only for starting holes or fasteners.

NOTE: Continuous use in variable speed range is not recommended. It may damage the switch and should be avoided.

FORWARD / REVERSE CONTROL BUTTON

A forward/reverse control button determines the direction of the tool and also serves as a lock off button. To select forward rotation, RELEASE THE VARIABLE SPEED SWITCH (see Fig. 1A), and depress the forward/reverse control button (see Fig. 1B), toward left side of the tool. To select reverse, depress the forward/reverse control button, toward right side of the tool. The center position of the control button locks the tool in the off position. When change the position of the control button, making sure the trigger is released.

NOTE: The first time the tool is run after changing the direction of rotation, you may hear a click on start up. This is normal and does not indicate a problem.

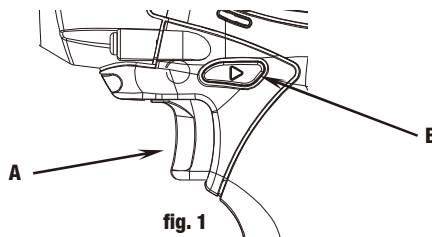

BUILT-IN LED LIGHT

A built-in LED light can illuminate the work area and improve vision when drilling/driving in areas with insufficient light.

ELECTRIC BRAKE

The variable speed switch is equipped with a circuit design electric of brake function. The tool will consistently operate to quickly stop rotating after the switch release.

ASSEMBLY

INSTALLING OR REMOVING BATTERY PACK

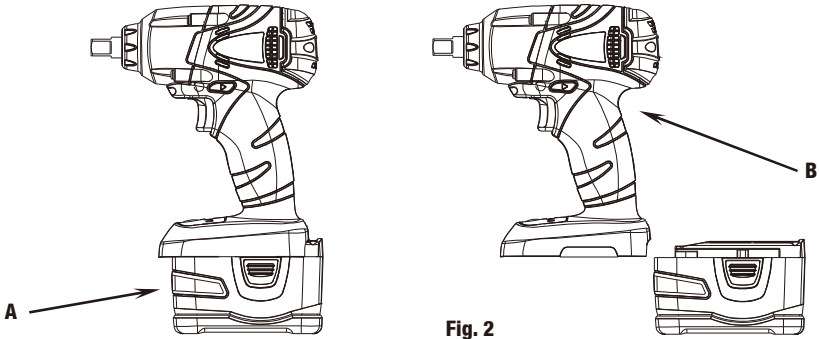

Fig. 2

TO REMOVE BATTERY PACK: Depress the battery release button and pull battery pack (A) out of tool (B). (see Fig. 2)
TO INSTALL BATTERY PACK: Push battery pack (A) onto tool until it locks in place. (see Fig. 2)

INSTALLING SOCKETS

Always follow the procedure below to install a socket.

1. Insert a socket into the anvil. (see Fig. 3)
2. Make sure the bit is fixed in the anvil while clicking on the ball of the anvil.

REMOVING SOCKETS

Always follow the procedure below to remove a socket.

1. Pull out the socket from the anvil directly. (see Fig. 3)

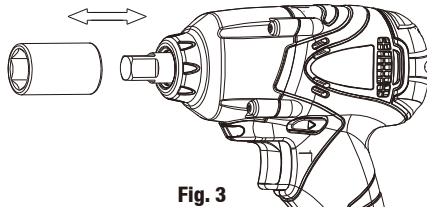

Fig. 3

OPERATION

1. After continuous use, allow the impact wrench/driver to sit idle for 15 minutes before replacing the battery. The temperature of the motor, switch, etc., will rise if the work is started again immediately after the battery has been changed, eventually resulting in burned-out.
2. Place the point of the bolt in the socket. Keep the tool pointed straight at the bolt.
3. Apply forward pressure to the tool to prevent the socket from slipping off the bolt.
4. To start, turn impact wrench/driver on. Always check torque with a torque wrench. The fastening torque can be affected by many factors including the following:

VOLTAGE

Low voltage due to a nearly discharged battery will reduce the fastening torque.

SOCKET SIZE

Failure to use the correct socket size will cause a reduction in fastening torque.

VARIABLE SPEED TRIGGER SWITCH

Operating the tool at a reduced speed will reduce the fastening torque.

BOLT SIZE

Larger bolt diameters generally require higher fastening torque. Fastening torque will also vary according to length, grade, and torque coefficient.

MATERIAL

The type of material and surface finish of the material will affect fastening torque.

FASTENING TIME

Longer fastening time results in increased fastening torque. Using a longer fastening time than recommended could cause the screws to be overstressed, stripped or damaged.

MAINTENANCE

CLEANING

With the motor running, blow dirt and dust out of all air vents with dry air at least once a week. Wear safety glasses when performing this. Exterior plastic parts may be cleaned a damp cloth and mild detergent. Although these parts are highly solvent resistant, NEVER use solvent.

CHARGER CLEANING INSTRUCTIONS

Dirt and grease may be removed from the exterior of the charger using a cloth or soft non-metallic brush. Do not use water or any cleaning solutions.

WARNING! Disconnect the charger from the AC outlet before cleaning solutions.

ACCESSORIES

Recommended accessories for use with your tool are available at extra cost from your local service center.

IMPORTANT: To assure product SAFETY and RELIABILITY, repairs, maintenance and adjustment (including brush inspection and replacement) should be performed by certified service centers or other qualified service organizations, always using identical replacement parts.

NOTE: Before disposing of damaged, check with your state Environmental Protection Agency to find out about special restrictions on the disposal of tool or return them to a KRAFTWERK certified service center for recycling.



© KRAFTWERK Europe AG

DECLARATION OF CONFORMITY

Model: **32103**

LI-ION CORDLESS IMPACT WRENCH 18 V 1/2" 850 Nm WITH DIGITAL CLUTCH

KRAFTWERK Sàrl, 25 rue due Stade, F-67870 Bischoffsheim

Declares under sole responsibility that the product to which this declaration relates is in conformity with the following standard(s) or other normative document(s):

EN 60745-1:+A11
EN 60745-2-2
Annex-1 of 2006/42/EC

Following the provisions of Directive(s)
Machinery Directive:

2006/42/EC
2014/30/EU

Bischoffsheim, 06/05/2015

Patrick Wyss
President

GENERAL SAFETY RULES FOR CHARGER AND BATTERY PACK

WARNING! Read and Understand All Instructions.

Failure to follow all instructions listed below may result in electric shock, fire and/or serious personal injury.

SAVE THESE SAFETY INSTRUCTIONS

NOTE: This instruction manual contains important safety and operation procedures for the designated battery packs and charger. Before using the battery packs and charger, read this manual, the matching tool's instruction manual, and all labels on the battery packs, charger and tool.

1. **To reduce the risk of injury, charge the designated battery packs only in the designated chargers.** Other types of chargers may cause personal injury or damage. Do not wire a battery pack to a power supply plug or car cigarette lighter. Battery packs will be permanently disabled or damaged.
2. **Use the designated battery packs only on the designated tools.** Use with other tools may result in risk of fire, electric shock or personal injury.
3. **Avoid dangerous environments.** Do not charge battery pack in rain, snow, damp or wet locations. Do not use battery pack or charger in the presence of explosive atmospheres (gaseous fumes, dust or flammable materials) because sparks may be generated when inserting or removing battery pack, possibly causing fire.
4. **Charge in a well ventilated area.** Do not block charger vents. Keep them clear to allow proper ventilation. Do not allow smoking or open flames near a charging battery pack. Vented gases may explode.
5. **Maintain charger cord.** When unplugging charger, pull plug rather than cord to reduce the risk of damage to the electrical plug and cord. Never carry charger by its cord. Keep cord away from heat, oil and sharp edges. Make sure cord will not be stepped on, tripped over or subjected to damage or stress. Do not use charger with damaged cord replaced immediately with identical replacement parts.
6. **Do not use an extension cord unless it is absolutely necessary.** Using the wrong, damaged or improperly wired extension cord could result in the risk of fire and electrical shock. If an extension cord must be used, plug the charger into a properly wired 16 gauge or larger extension cord with pins that are the same number, size and shapes as the pins on the charger. Make sure that the extension cord is in good electrical condition.
7. **Charger is rated for 100-240 volt AC only.** Charger must be plugged into an appropriate receptacle.
8. **Use only recommended attachments.** Use of an attachment not recommended or sold by the battery charger or battery pack manufacturer may result in a risk of fire, electric shock or personal injury.
9. **Unplug charger when not in use.** Remove battery packs from unplugged chargers.
10. **To reduce the risk of electric shock, always unplug charger before cleaning or maintenance.** Use a Ground Fault Circuit Interrupter (GFCI) to reduce shock hazards.
11. **Do not burn or incinerate battery packs.** Battery packs may explode, causing personal injury or damage. Toxic fumes and materials are created when battery packs are burned.
12. **Do not crush, drop, or damage battery packs.** Do not use a battery pack or charger that has received a sharp blow, been dropped, run over, or damaged in any way.
13. **Do not disassemble.** Incorrect reassembly may result in the risk of electric shock, fire or exposure to battery chemicals. If it is damaged, take it to an authorized service center.
14. **Battery chemicals cause serious burns.** Never allow contact with skin, eyes, or mouth. If a damaged battery pack leaks battery chemicals, use rubber or neoprene gloves to dispose of it. If skin is exposed to battery fluids, wash with soap and water and rinse with vinegar. If eyes are exposed to battery chemicals, immediately flush with water for 20 minutes and seek medical attention. Remove and dispose of contaminated clothing.
15. **Do not short circuit.** Battery packs will short circuit if a metal object make a connection between the positive and negative contacts on the battery pack. Do not place a battery pack near anything that may cause a short circuit, such as coins, keys or nails in your pocket. A short-circuited battery pack may cause fire and personal injury.
16. **Store your battery pack and charger in a cool, dry place.** Do not store battery pack where temperatures may exceed 105°F (40.5°C) such as in direct sunlight, a vehicle or metal building during the summer. Charger will charge the battery when the battery's internal temperature is between 32°F (0°C) and 113°F (45°C). When the battery temperature is outside that range, charging will not occur.
17. This appliance is not intended for use by persons (including children) with reduced physical, sensory or mental capabilities, or lack of experience and knowledge, unless they have been given supervision or instruction concerning use of the appliance by a person responsible for their safety.

18. Children should be supervised to ensure that they do not play with the appliance.
19. If the supply cord is damaged, it must be replaced by the manufacturer or its service agent or similar qualified person in order to avoid a hazard.

BATTERY CARE

WARNING! When batteries are not in tool or charger, keep them away from metal objects. For example, to protect terminals from shorting DO NOT place batteries in a tool box or pocket with nails, screws, keys, etc. Fire or injury may result.

DO NOT PUT BATTERIES INTO FIRE OR EXPOSE TO HIGH HEAT. They may explode.

BATTERY DISPOSAL

WARNING! Do not attempt to disassemble the battery or remove any component projecting from the battery terminals. Fire or injury may result. Prior to disposal, protect exposed terminals with heavy insulating tape to prevent shorting.



NOTE: Before disposing of damaged, check with your state Environmental Protection Agency to find out about special restrictions on the disposal of tool or return them to a certified service center for recycling.

GUIDELINES FOR USING EXTENSION CORDS

WARNING! If you are using an extension cord outdoors, be sure it is acceptable for outdoor use.

Be sure your extension cord is properly wired and in good electrical condition. Always replace a damaged extension cord or have it repaired by a qualified person before using it.

Protect your extension cords from sharp objects, excessive heat, and damp or wet areas.

Recommended Minimum Wire Gauge for Extension Cords

Nameplate Amperes	Extension Cord Length					
	25 ft	50 ft	75 ft	100 ft	150 ft	200 ft
0 - 5	16	16	16	14	12	12
5.1 - 8	16	16	14	12	10	-
8.1 - 12	14	14	12	10	-	-
12.1 - 15	12	12	10	10	-	-
15.1 - 20	10	10	10	-	-	-

FUNCTIONAL DESCRIPTION

SYMBOLS

V	Volts		Alternating Current
A	Amperes		Direct Current
Hz	Hertz		Class II Construction

SPECIFICATIONS

Charger					
Model Number	Type	Input (AC)	Input Power	Output (DC)	Output Amps
32101AL	Li-ion	220-240 V 50 Hz	100 W	20.6 V	4.0

Battery Pack	
Model Number	Volts (DC)
32101AK	18 V

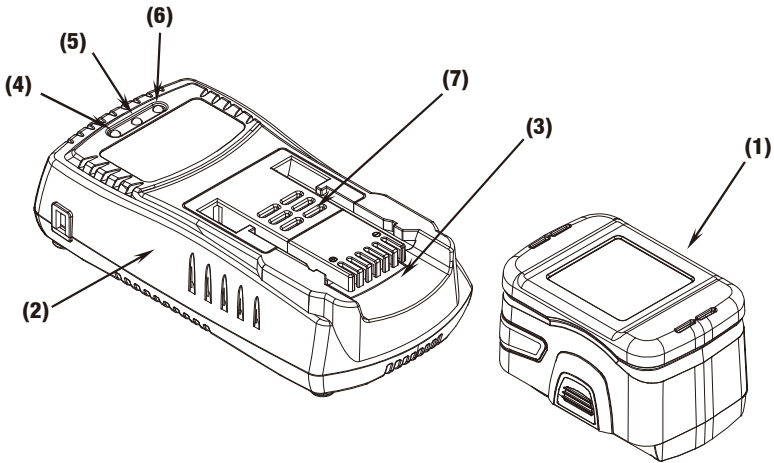

(1) Battery Pack

(2) Charger

(3) Battery Compartment

(4) Green LED Indicator

(5) Red LED Indicator

(6) Yellow LED Indicator

(7) Air-Cool Vent

Charger Light Indicator		
LED Indicator		Situation
Yellow		
Blinking Light		Battery pack is inserted
Red	Green	
Steady Light	No Light	Standing by (when no battery pack is inserted)
No Light	Blinking Light	Charging
No Light	Steady Light	Charging is complete
Blinking Light	Blinking Light	Battery pack is too hot or too cold (charging will begin automatically when battery reaches correct charging temperature)
Blinking Light	No Light	Damaged or faulty battery pack

CHARGING BATTERY PACK INSTRUCTIONS

1. Make sure power circuit voltage is the same as that shown on the charger specification plate. Connect charger to power source. Red light (5) should light up. This indicates the charger is ready to begin charging.
2. Position a battery pack (1) on charger (2); align rails on battery compartment (3). Slide battery forward onto charger until it stops. Yellow light (6) should blink. That indicates a 32101AK battery pack is inserted.
3. And the red light will go out and green light (4) begins to blink continuously, indicating that the battery pack is receiving a "Fast Charge".
4. After approximately 60 minutes, the battery pack is fully charged. The green light will become steady.
5. Disconnect the battery pack and the charger in turn (unless you would like to charge another battery pack, or to leave the battery pack on Trickle-Charge mode until you are ready to use it.)

NOTE: The steady green light indicates that the battery pack is fully charged or in slow charging mode to maintain battery pack charge level.

NOTE: Depending on room temperature, line voltage, and existing charge level, initial battery charging may take longer than 60 minutes.

NOTE: After normal use, the battery pack will require 60 minutes of charging before it will be fully charged. A completely discharged battery will require more than 60 minutes in order to be fully charged.

NOTE: Disconnect charger from power source when not in use.

IMPORTANT CHARGING NOTES

1. Longest life and best performance can be obtained if the battery pack is charged when the surrounding air temperature is between 65°F (18°C) and 75°F (24°C). DO NOT charge battery pack in an air temperature below 40°F (4.5°C), or above 105°F (40.5°C). This is important and will prevent serious damage to battery pack.
2. The charger was designed to fast charge battery pack between 32°F (0°C) and 113°F (45°C). If the battery pack just inserted is too cold or too hot, the charger will not charge it and only the green LED indicator and the red LED indicator will blink alternatively and continuously. After the battery pack temperature fit standard temperature range, the fast charging procedure will be started automatically.
3. If battery pack is not charged properly (the red LED indicator will blink):
 - a. Check battery pack terminals for dirt. Clean with cotton swab and alcohol if necessary.
 - b. If battery pack is not still charged properly, take or send charger (and battery pack) to the closest Authorized Service Center.

4. Under certain conditions, with the charger plugged into the power source, the exposed charging contacts inside the charger can be shorted by foreign material. Foreign materials of a conductive nature such as, but not limited to, steel wool, aluminum foil, or any buildup of metallic particles should be kept away from charger cavities. Always unplug the charger from the power source when there is no battery pack in the battery compartment. Unplug charger before attempting to clean.
5. Do not freeze or immerse charger in water or any other liquid.

WARNING! Don't allow any liquid to get inside charger. Electric shock may result. To facilitate the cooling of the battery pack after use, avoid placing the charger in a warm environment such as in a metal shed, or an uninsulated trailer.

CAUTION: Never attempt to open the charger for any reason. If the plastic housing of the charger breaks or cracks, return to the closest Authorized Service Center.

IMPORTANT: This product is not user serviceable. There are no user serviceable parts inside the charger. Servicing at the closest Authorized Service Center is required to avoid damage to static sensitive internal components. READ ALL OF THE INSTRUCTIONS IN THE BATTERY CHARGER SECTION OF THIS MANUAL BEFORE ATTEMPT TO CHARGE THE BATTERY PACK FOR YOUR TOOL.

Always use correct battery pack (pack supplied with tool or replacement pack exactly like it.) Never install any other battery pack. It will ruin your tool and may create a hazardous condition.

IMPORTANT BATTERY PACK NOTES

1. 32101AK series battery pack can remain in the charger without damaging the battery or the charger. The battery will remain fully charged in the charger.
2. If you remove the battery pack from the battery compartment before the battery is fully charged, it will not cause any damage to the battery.
3. If several charging operations are performed consecutively, the charger can become warm. It is normal and does not indicate any technical defect.

CAUTION: DO NOT USE THE BATTERY PACK if it is damaged and liquid is leaked from the battery pack cells. If this leakage gets on your skin, please wash affected part immediately and observe any skin reaction. If necessary, please seek medical attention.

MAINTENANCE

CLEANING INSTRUCTIONS

WARNING! Disconnect charger from DC outlet before cleaning. Dirt and grease may be removed from the exterior of the charger by using a cloth or a soft non-metallic brush. Do not use water or any cleaning solutions.

IMPORTANT: To ensure product SAFETY and RELIABILITY, repairs, maintenance and adjustments should be performed by a qualified technician, who always using identical replacement parts.

DECLARATION OF CONFORMITY

Model: **32101AL**

LI-ION 60 MIN. FAST CHARGER 18 V

KRAFTWERK Sàrl, 25 rue due Stade, F-67870 Bischoffsheim

Declares under sole responsibility that the product to which this declaration relates is in conformity with the following standard(s) or other normative document(s):

EN 55014-1:2006+A1

EN 55014-2:1997+A1+A2

EN 61000-3-2:2006+A1+A2

EN 6100-3-3:2008

Following the provisions of Directive(s)

Machinery Directive:

2014/35/EU

2014/30/EU

Bischoffsheim, 28/02/2013



Patrick Wyss
President

WARRANTY

We do not take responsibility for any damage caused by misuse or any use that is not in compliance with the safety standards described herein.

Customer services

Contact your local importer or your specialized dealer to obtain address of your service department.

You find our partners under **www.KRAFTWERKtools.com**



From date of purchase receipt

2 YEARS GUARANTEE

on material- or production-defects



KRAFTWERK Europe AG
Mettlenbachstrasse 23
CH-8617 Mönchaltorf
Switzerland
Tel. +41-44 949 40 50

KRAFTWERK Sàrl.
25, rue du Stade
F – 67870 Bischoffsheim
France
Tel. +33-388 48 64 50

www.KRAFTWERKtools.com